

Module CN03 of the BITREK CONNECT system



Purpose of the device

The CN03 module of Bitrek Connect system is intended for to control technical operating parameters of vehicles equipped with the CAN bus and transmit these parameters to the Connect-Bus. In addition, the module can work with fuel level sensors fuel level sensors, RFID-readers and threshold sensors via interface RS-485.

Package Contents

The CN03 of Bitrek Connect comes with the following configuration:

- CN03 module - 1 pc;
- Data sheet - 1 pc;
- Warranty card - 1 pc;
- Packing box - 1 pc.
- MicroFit 4-pin cable - 1 pc.
- MicroFit 6-pin cable - 1pc.
- Rubber seal - 3 pcs.

Technical characteristics of the device

Technical characteristics of the device are presented in Table 1.

Table 1: Technical specifications of the device

Parameters	Characteristics
Supply voltage	12 V or 24 V
Type of current consumption	(12V) 50mA
Interface for connection of fuel level sensors, RFID readers and threshold sensors	RS485
CAN standard	29 bit (FMS), 11 bit
Maximum number of fuel level sensors	8
Maximum number of RFID readers	4
Maximum number of threshold sensors	15
Operating temperature	from -30 °C to +80 °C
Allowable humidity	80 +/- 15%
Dimensions (W x L x H)	78 x 83 x 30 mm
Protection class of enclosure	IP44
Net weight	80 gr.
gross weight	110 g

Appearance and dimensions of the device

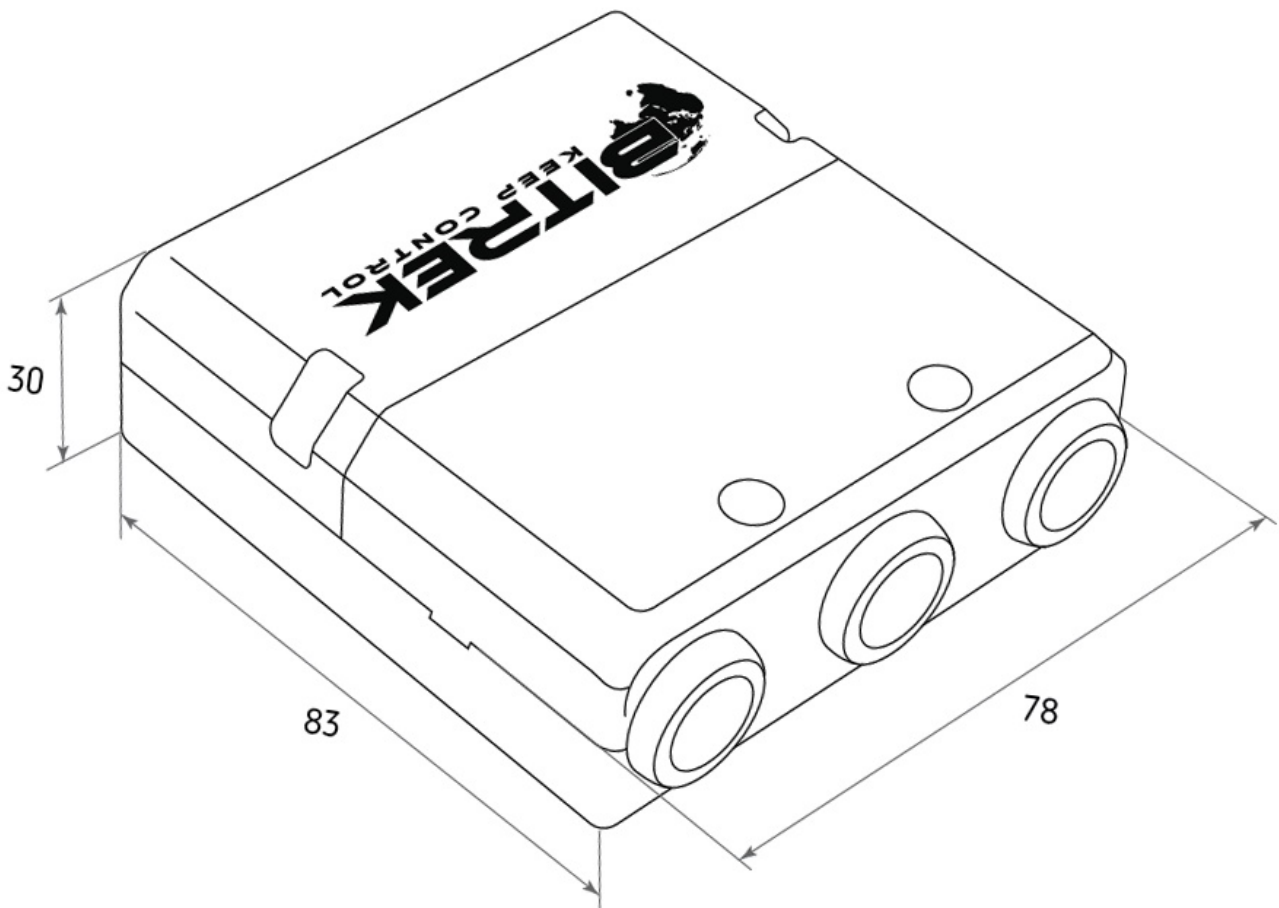

Fig.1. Appearance and dimensions

Pin assignment

The CN03 module is equipped with three Micro-Fit connectors (Fig. 2).



Fig.2. The appearance of the connectors

The four-pin connectors (Fig. 3) are Connect-Bus connectors, which have the power outputs of the module and the outputs signal lines of the bus.

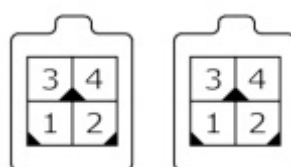

Fig.3. Connect-Bus connectors #1 and #2

The pinout of the Connect-Bus connectors is shown in Table 2.

Table 2 The pin-out of the Connect-Bus connectors No.1 and No.2

No	Pin name	Signal type	Pin assignment
1	GND	Power supply	General lead (ground)
2	CAN L	Input/output	Signal "CAN_L" of the CAN bus
3	+ Vin	Power supply	"+" On-board power supply (nominal voltage 12 V or 24 V)
4	CAN H	input/output	Signal "CAN_H" on the CAN bus

The six-pin connector (Fig.4) is the connector for fuel level sensors, threshold sensors and RFID readers. It has power outputs of sensors, RS485 signal lines and signal lines of the vehicle CAN bus.



Fig.4. Connector for connecting external devices

The pinout of the connector for connecting external devices is presented in table 3.

Table 3. External device connector pinout

No	Pin name	Signal type	Pin assignment
1	GND	power supply	common ground
2	CAN H	input/output	CAN_H signal
3	RS485 A	input/output	RS485 "A" signal
4	+ Vin	Power output	"+" on-board power supply (to power external devices)
5	CAN L	input/output	"CAN_L" signal on the CAN bus
6	RS485 B	input/output	RS485 "B" signal

Description of indications

On the front panel of the module, on the connector side, there are two LEDs on the connector side of the front panel, which indicate the current status of the device.

Red LED - blinks when RS-485 communication is successful

Green LED - lights steadily when the device continuously illuminates when device is successfully started up.

Setting up the CN03 module

The CN03 has a number of configurable parameters of which are listed in Appendix 1. To configure the module module, the Bitrek Connect configurator module is used, as well as Connect Configurator software. How to work with the configurator module and Software are described in detail in the "Guidelines for organizing and configuring Bitrek Connect".

Configuring the module to work with arbitrary PGN

Parameters FMSPGN00 to FMSPGN19 are used to configure arbitrary PGNs with a bit size of 11 bits or 29 bits expected on the CAN bus of the vehicle and transmitted to the Connect- Bus, with address swapping to the current address of the module on the bus. If parameter is zero, this PGN is considered disabled and is not is considered to be disabled and does not participate in operation. These parameters are set in HEX view and have the following format:

PRIO PGN ADDR.

where:

PRIO - message priority;

PGN is the message body (PGN);

ADDR is the sender's address.

For example: there is a need to set up an arbitrary PGN 18FEE900 (Fuel Consumption: LFC, 1000 mS).

To do this, the value 18FEE900 (Fuel Consumption: LFC: 1000 mS) must be entered in the "Arbitrary PGN00" parameter (ID7800) write the value 18FEE900 (Fig.5). Then set the digit capacity PGN00 parameter is 29 bits, since this PGN is 29- bit (Fig.6). This can be done using the Connect Configurator.



Figure 5. Setting the value of an arbitrary PGN



Fig.6. Setting the arbitrary PGN bit value

The CAN reception filter will then be configured to receive messages from CANID 18FEE900. After receiving such a message the current address of the message will be replaced by the peripheral address of the CN03 module and it will be broadcast to the Connect-Bus.

Configuring the module for operation with fuel level sensors

Each fuel level sensor connected to the CN03 module must be preset. The adjustment includes is to assign each sensor on the RS485 bus a network address. After the network addresses of fuel level sensors are assigned, you can configure the CN03 module.

Open the tree-like list of the module parameters by pressing the "+" symbol. The Settings group is displayed in the list. In the subgroup "RS485 remote control unit" you must configure the following parameters: "Address RS485 address" (Fig.7) and "Resolution of RS485 polling" (Fig.8). Parameters "Interval Interrogation period" and "Time of FLS transfer to Connect-Bus" parameters can be left unchanged. leave them unchanged.



Fig.7. Fuel level sensor address assignment

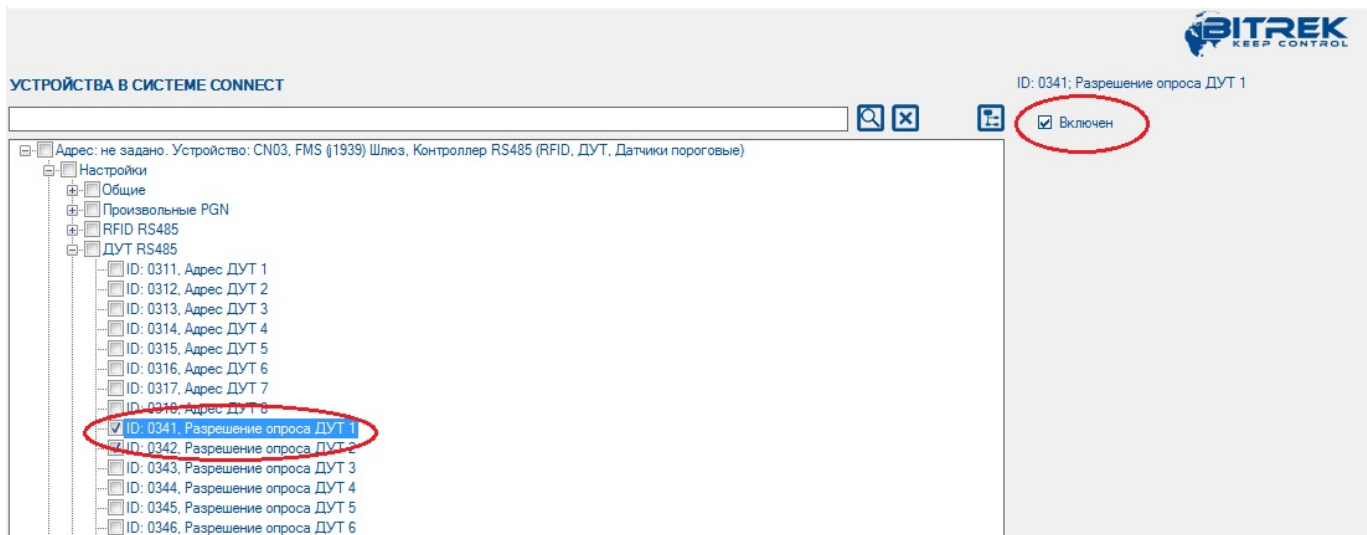

Fig.8. Sensor polling permission

After that the CN03 module will poll the fuel level sensor, which is on the 1st network address on the bus RS485 BUS. The received data message will be translated into the Connect-Bus.

Setting up the module to work with RFID readers

Setting up the module to work with RFID readers the module is configured in the same way. In the “RFID RS485” setting group, you must specify the reader address on the RS485 bus and enable the module to interrogate it. Parameters “RFID polling period” and The “Period of RFID transmission to Connect-Bus” parameters can be left unchanged.

Note:

The communication between RFID readers and the CN03 module according to the RCS SOVA protocol

Configuring the module to work with RS485 threshold sensors

Each threshold sensor connected to the module must be pre-configured. The configuration comes down to setting up a unique network address on the RS485 bus for each threshold network address on the RS485 bus for each threshold sensor. To configure the network address of the threshold sensors The FL Configurator software is used to set the network address.

Note:

The network addresses of the threshold sensors must not be the same as Note: The network addresses of the threshold sensors must not be the same as the network addresses of the fuel level sensors in use.

Then in the subset of the CN03 “Threshold Sensors RS485 sensors” subgroup of the CN03 module settings, you need to enable the sensor polling, specify its network address on the RS485 bus, specify upper and lower thresholds of operation (Fig.9). These parameters must be configured separately for each of used threshold sensors.

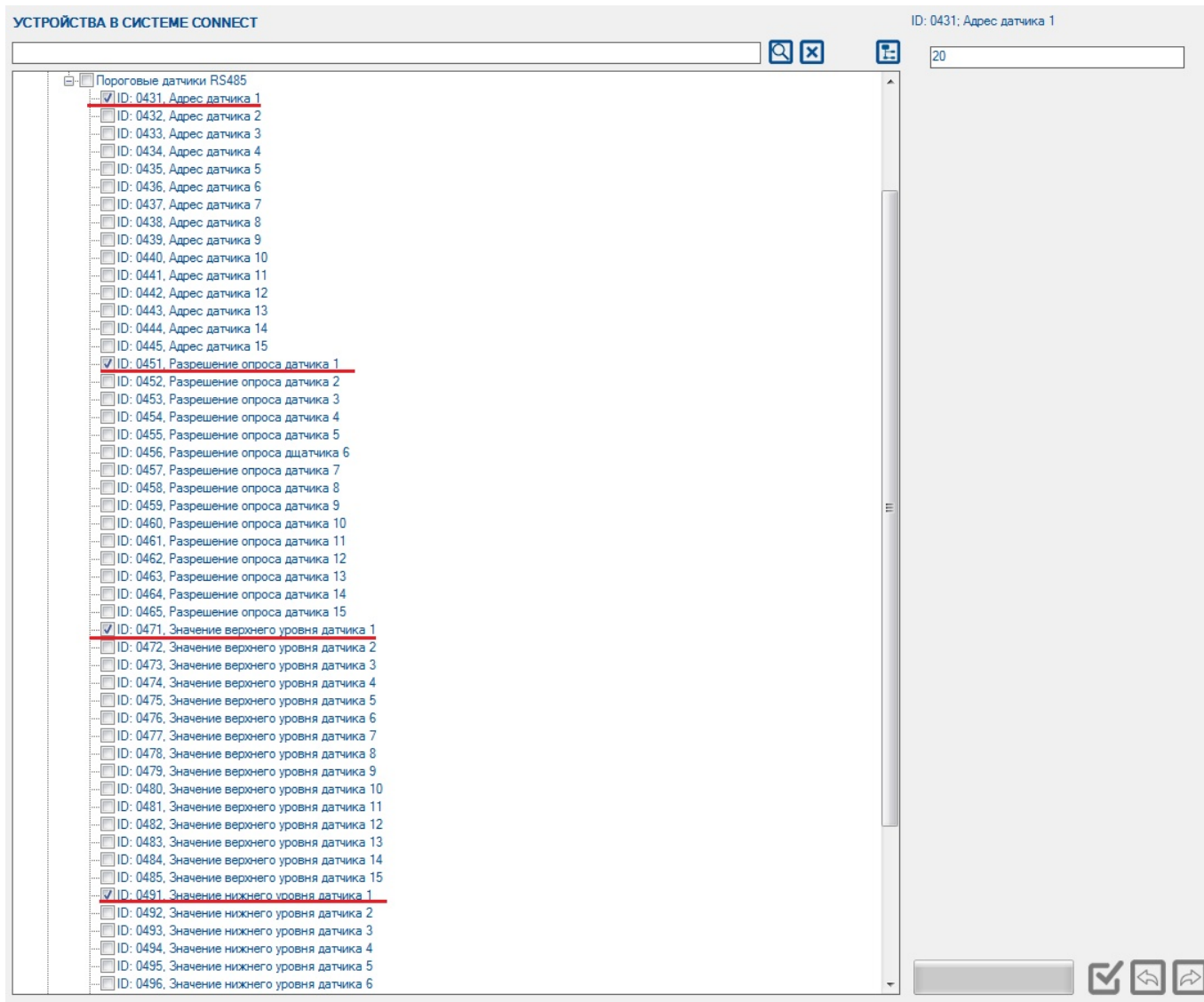

Figure 9. Setting up the RS485 threshold sensors

Up to 15 sensors can be connected to the module simultaneously. In this case it is recommended to allow polling only actually connected sensors. There are 15 parameters in the CN03 settings (id 431 - id 445) to specify the network addresses of the connected sensors. When specifying the network addresses, the following principle should be followed: The network address of the the net address of the lowermost sensor must be entered in the parameter corresponding to the 1st sensor. the parameter corresponding to the 1st sensor in the CN03 module and then in order.

Note:

The upper and lower thresholds are set according to Note: The upper threshold can be adjusted as below.

The “Upper Threshold “ is the sensor value above which the CN03 decides above which the CN03 decides that the sensor has triggered. The value written in this field should be 15- 35% less than the actual value obtained with with the sensor immersed in the grain. This is to ensure that the sensor of the sensor operation.

“Lower threshold “ is the sensor value at which the CN03 module decides that the sensor has gone from the active “triggered” state to the inactive state. The value written in This field should be 15-35% greater than the actual value of the empty sensor.

Sample of setting: Threshold sensors are mounted in the hopper, hopper empty, all sensors have the zero level calibrated at 100 c.u. level. The hopper is then filled with grain so that several sensors are filled. After filling their readings must be recorded. For example: The filled sensors showed a level of 200. In this case, in the “Upper threshold” field you must 170, and in the “Lower Threshold” field - 130.

Preset PGNs of FMS standard

The CN03 module has a group of preset FMS standard PGNs (J1939) that are monitored and transmitted to the Connect- Bus always, regardless of the settings of the arbitrary PGNs. A list of such PGNs are listed in Table 4.

The principle of operation of the device is as follows: The module receives all messages whose CANID contains a PGN from the list of preset list, ignoring the priority of the message and the ignoring the priority of the message and the sender address. The received CANIDs are transmitted to the Connect-Bus with priority 0x18 and the address of the CN03 module.

Table 4. List of preset PGNs

No.	PGN	Description
1	0x18FEE900	amount of fuel used
2	0x18FEFC00	Fuel level
3	0x18FEF200	hourly fuel consumption
4	0x18FEF200	Instantaneous fuel economy
5	0x18FD0900	High-resolution fuel consumption total
6	0x18F00400	Engine RPMs
7	0x18F00400	Actual engine torque
8	0x18FEE500	Engine running time
9	0x18FEEE00	engine coolant temperature
10	0x18F00300	engine load percentage at current speed
11	0x18F00500	Gearbox current gearbox
12	0x18F00500	Selected transmission gear
13	0x18FEE800	Compass bearing
14	0x18FEE800	GPS/GLONASS speed
15	0x18FEE800	GPS/GLONASS angle deviation
16	0x18FEE800	GPS altitude
17	0x18FEF300	Latitude
18	0x18FEF300	Longitude
19	0x18FEC100	Vehicle Mileage
20	0x18FEF500	Ambient temperature
21	0x18FEF100	Vehicle speed determined by the rotation of the wheels
22	0x18FEF100	clutch pedal
23	0x18FEF100	brake pedal
24	0x18FEF100	cruise control
25	0x18F00300	Accelerator pedal position 1

No.	PGN	Description
26	0x18FE7000	Total vehicle weight
27	0x18FEF100	parking brake switch
28	0x18FE4E00	Door position 2
29	0x18FE4E00	Door position

List of variables broadcast to the CONNECT-BUS

Nº	Parameter Name	Size	PGN	Start Bit	Bit Total	Time Out
Systems						
1	Device model	4	18F713	0	32	10
2	software version	4	18F713	32	32	10
3	module operating time	4	18F712	0	32	10
4	number of module restarts	4	18F712	32	32	10
CAN J1939 (FMS Standard)						
5	Fuel consumption	4	18FEE9	32	32	0
6	Fuel level 1	1	18FEFC	8	8	0
7	hourly fuel consumption	2	18FEF2	0	16	5
8	Instantaneous fuel economy	2	18FEF2	16	16	5
9	High-resolution fuel economy	4	18FD09	32	32	0
10	engine rpm	2	18F004	24	16	5
11	motor running time	4	18FEE5	0	32	0
12	Engine coolant temperature	1	18FEEE	0	8	5
13	Engine load percentage at current speed	1	18F003	16	8	5
14	actual engine torque	1	18F004	16	8	5
15	current gearbox	1	18F005	24	8	5
16	selected gearbox	1	18F005	0	8	5
17	Compass azimuth	2	18FEE8	0	16	0
18	GPS/GLONASS speed	2	18FEE8	16	16	0
19	GPS/GLONASS angle deviation	2	18FEE8	32	16	0
20	GPS/GLONASS altitude	2	18FEE8	48	16	0
21	GPS/GLONASS latitude	4	18FEF3	0	32	0
22	GPS/GLONASS Longitude	4	18FEF3	32	32	0
23	Vehicle Mileage	4	18FEC1	0	32	0
24	ambient temperature	2	18FEF5	24	16	5
25	Vehicle speed determined by the movement of the wheels	2	18FEF1	8	16	5
26	Clutch pedal	1	18FEF1	30	2	5
27	brake pedal	1	18FEF1	28	2	5
28	cruise control	1	18FEF1	24	2	5
29	Accelerator pedal position 1	1	18F003	8	8	5
30	Total weight of the vehicle	2	18FEF70	16	16	0
31	parking brake switch	1	18FEF1	2	2	0
32	Door position 2	1	18FE4E	6	2	0

No	Parameter Name	Size	PGN	Start Bit	Bit Total	Time Out
33	door position	1	18FE4E	0	4	0
DROPPED RS485						
38	FLS status 1	1	18F709	0	1	10
39	FLS 2 status	1	18F70A	0	1	10
40	FLS 3 status	1	18F70B	0	1	10
41	FLS 4 status	1	18F70C	0	1	10
42	FLS 5 status	1	18F70D	0	1	10
43	FLS status 6	1	18F70E	0	1	10
44	FLS 7 status	1	18F70F	0	1	10
45	FLS status 8	1	18F710	0	1	10
46	Temperature of FLS 1	1	18F709	16	8	10
47	Temperature of FLS 2	1	18F70A	16	8	10
48	Temperature of FLS 3	1	18F70B	16	8	10
49	Temperature of FLS 4	1	18F70C	16	8	10
50	Temperature of FLS 5	1	18F70D	16	8	10
51	Temperature of FLS 6	1	18F70E	16	8	10
52	Temperature of FLS 7	1	18F70F	16	8	10
53	FLS 8 temperature	1	18F710	16	8	10
54	Fuel FLS 1	2	18F709	24	16	10
55	FLS fuel 2	2	18F70A	24	16	10
56	FLS fuel 3	2	18F70B	24	16	10
57	FLS fuel 4	2	18F70C	24	16	10
58	FLS fuel 5	2	18F70D	24	16	10
59	FLS fuel 6	2	18F70E	24	16	10
60	FLS fuel 7	2	18F70F	24	16	10
61	Fuel FLS 8	2	18F710	24	16	10
RFID RS485						
62	RFID status 1	1	18F701	0	2	5
63	RFID status 2	1	18F702	0	2	5
64	RFID status 3	1	18F703	0	2	5
65	RFID Status 4	1	18F704	0	2	5
66	RFID card number 1	8	18F701	16	40	5
67	RFID card number 2	8	18F702	16	40	5
68	RFID card number 3	8	18F703	16	40	5
69	RFID card number 4	8	18F704	16	40	5
RS485 threshold sensors						
70	Level bitmask	2	18F720	0	16	5
71	grain level	2	18F720	16	16	5
72	Upper threshold	2	18F720	32	16	5
73	bitmask of allowed sensors	2	18F721	0	16	5
74	Bit mask of connected sensors	2	18F721	16	16	5
75	Threshold sensor 1 on RS485 bus	1	18F731	0	8	5
76	Threshold sensor 2 on the RS485 bus	1	18F732	0	8	5
77	Threshold sensor 3 on the RS485 bus	1	18F733	0	8	5

№	Parameter Name	Size	PGN	Start Bit	Bit Total	Time Out
78	RS485 bus threshold sensor 4	1	18F734	0	8	5
79	RS485 bus threshold sensor 5	1	18F735	0	8	5
80	RS485 bus threshold sensor 6	1	18F736	0	8	5
81	RS485 bus threshold sensor 7	1	18F737	0	8	5
82	RS485 bus threshold sensor 8	1	18F738	0	8	5
83	RS485 bus threshold sensor 9	1	18F739	0	8	5
84	RS485 bus threshold sensor 10	1	18F73A	0	8	5
85	RS485 bus threshold sensor 11	1	18F73B	0	8	5
86	RS485 bus threshold sensor 12	1	18F73C	0	8	5
87	RS485 bus threshold sensor 13	1	18F73D	0	8	5
88	RS485 bus threshold sensor 14	1	18F73E	0	8	5
89	RS485 bus threshold sensor 15	1	18F73F	0	8	5
90	State of sensor 1	1	18F731	8	8	5
91	State of sensor 2	1	18F732	8	8	5
92	State of sensor 3	1	18F733	8	8	5
93	Sensor 4 condition	1	18F734	8	8	5
94	Sensor 5 condition	1	18F735	8	8	5
95	Sensor 6 condition	1	18F736	8	8	5
96	sensor 7 condition	1	18F737	8	8	5
97	Sensor 8 condition	1	18F738	8	8	5
98	Sensor 9 condition	1	18F739	8	8	5
99	Sensor 10 condition	1	18F73A	8	8	5
100	Sensor 11 condition	1	18F73B	8	8	5
101	State of sensor 12	1	18F73C	8	8	5
102	State of sensor 13	1	18F73D	8	8	5
103	Sensor 14	1	18F73E	8	8	5
104	Sensor 15	1	18F73F	8	8	5
105	Temperature sensor 1	1	18F731	16	8	5
106	Temperature sensor 2	1	18F732	16	8	5
107	Temperature sensor 3	1	18F733	16	8	5
108	Temperature sensor 4	1	18F734	16	8	5
109	Temperature sensor 5	1	18F735	16	8	5
110	Temperature sensor 6	1	18F736	16	8	5
111	temperature sensor 7	1	18F737	16	8	5
112	temperature sensor 8	1	18F738	16	8	5
113	temperature sensor 9	1	18F739	16	8	5
114	temperature sensor 10	1	18F73A	16	8	5
115	temperature sensor 11	1	18F73B	16	8	5
116	temperature sensor 12	1	18F73C	16	8	5
117	Temperature sensor 13	1	18F73D	16	8	5
118	temperature sensor 14	1	18F73E	16	8	5
119	Sensor temperature 15	1	18F73F	16	8	5
120	Sensor level 1	2	18F731	24	16	5
121	Sensor level 2	2	18F732	24	16	5

No	Parameter Name	Size	PGN	Start Bit	Bit Total	Time Out
122	Sensor level 3	2	18F733	24	16	5
123	Sensor level 4	2	18F734	24	16	5
124	Sensor level 5	2	18F735	24	16	5
125	Sensor level 6	2	18F736	24	16	5
126	Sensor level 7	2	18F737	24	16	5
127	Sensor level 8	2	18F738	24	16	5
128	Sensor level 9	2	18F739	24	16	5
129	Sensor level 10	2	18F73A	24	16	5
130	Sensor level 11	2	18F73B	24	16	5
131	Sensor level 12	2	18F73C	24	16	5
132	Sensor level 13	2	18F73D	24	16	5
133	Sensor level 14	2	18F73E	24	16	5
134	Sensor level 15	2	18F73F	24	16	5
135	Sensor polling resolution 1	1	18F731	56	8	5
136	Sensor polling resolution 2	1	18F732	56	8	5
137	Sensor 3 polling resolution	1	18F733	56	8	5
138	Sensor polling resolution 4	1	18F734	56	8	5
139	Sensor polling resolution 5	1	18F735	56	8	5
140	Sensor polling resolution 6	1	18F736	56	8	5
141	Sensor polling resolution 7	1	18F737	56	8	5
142	Sensor polling resolution 8	1	18F738	56	8	5
143	Sensor polling resolution 9	1	18F739	56	8	5
144	Sensor polling resolution 10	1	18F73A	56	8	5
145	Sensor polling resolution 11	1	18F73B	56	8	5
146	Sensor polling resolution 12	1	18F73C	56	8	5
147	Sensor polling resolution 13	1	18F73D	56	8	5
148	Sensor polling resolution 14	1	18F73E	56	8	5
149	Sensor polling resolution 15	1	18F73F	56	8	5

Supplement 1. Device parameters

Parameter name	ID when configured	Parameter digit	Parameter assignment	Default value
General				
CANSlaveAddr	0200	1 byte	device address on CONNECTBUS	1
DevicePIN	0400	4 bytes	Device access password	11111
CANSpeed	0201	1 byte	CAN speed setting	250 kbit/s
Arbitrary PGN				
PGNBitSize00 - PGNBitSize19	0401 - 0420	1 byte	1 byte Setting the arbitrary PGN bit rate	0 (off)
FMSPGN00 - FMSPGN19	7800 - 7819	4 bytes	PGN translated from vehicle CAN bus to CONNECT-BUS	0 (off)

Parameter name	ID when configured	Parameter digit	Parameter assignment	Default value
RFID RS485				
AddrSova1 - AddrSova4	0211 - 0214	1 byte	RFID SOVA address on the RS485 bus	1 - 4
Sova1Ena - Sova4Ena	0241 - 0244	1 byte	SOVA RFID polling permission	1
GetPeriodSova1 - GetPeriodSova4	0261 - 0264	2 bytes	SOVA RFID polling period (*100 ms)	100 (10 seconds)
SendPeriodSova1 - SendPeriodSova4	0281 - 0284	2 bytes	Period of sending RFID SOVA to CONNECT BUS (*100 ms)	10 (1 second)
RS485 REMOTE CONTROL				
Fuel1Addr - Fuel8Addr	0311 - 0318	1 byte	RS485 bus address	11 - 18
Fuel1Ena - Fuel8Ena	0341 - 0348	1 byte	Resolution of the FLS poll	1
GetPeriodFuel1 - GetPeriodFuel8	0361 - 0368	2 bytes	RTC polling period (*100 ms)	100 (10 seconds)
SendPeriodFuel1 - SendPeriodFuel8	0381 - 0388	2 bytes	period to send the RTC values to the CONNECT-BUS	10 (1 second)
RS485 threshold sensors				
AddrSens1 - AddrSens15	0431 - 0445	1 byte	RS485 threshold sensor address	20 - 34
Sens1Ena - Sens15Ena	0451 - 0465	1 byte	Threshold sensor polling permission	0 (off)
Sens1UpLimit - Sens15UpLimit	0471 - 0485	2 bytes	Threshold sensor upper level value	170
Sens1DownLimit - Sens15DownLimit	0491 - 0505	2 bytes	value of low level threshold sensor	120
GetPeriodSens1 - GetPeriodSens15	0397	2 bytes	polling period of all threshold sensors (*100 ms)	100 (10 seconds)
SendPeriodSens1 - SendPeriodSens15	0398	2 bytes	Period of sending values of all threshold sensors to the CONNECTBUS (*100 ms)	10 (1 second)

From:

<https://docs.bitrek.video/> - **Bitrek Video Wiki**

Permanent link:

<https://docs.bitrek.video/doku.php?id=en:cn03>

Last update: **2025/08/31 23:18**